

# ET77



## General Description

The ET77 has the best **performance/price** ratio, thanks to top-of-the-range features at the cost of a display balancing machine.

Low balancing speed, optimisation of average balancing speed, 7 ALU truck

and car programs, automatic acquisition of wheel/machine distance, adhesive weight application device, automatic weight application position search, visual wheel wobble inspection, automatic wheel type identification (truck/car), OPT

FLASH and 200kg lift with safety handle: these features, together with its original design, make the ET77 an exceptional purchase with an excellent quality/price ratio.

Car wheel balancing speed	120 rpm
Truck wheel balancing speed	80 rpm
Maximum unbalance value calculated	1990 g
Resolution	1 g
Average spin time for car wheels	8 s
Average spin time for truck wheels	18 s
Shaft diameter	46 mm
Rim width setting range for car wheels	1,5" ÷ 22"
Rim width setting range for truck wheels	4" ÷ 22"
Rim diameter setting range for car wheels	7" ÷ 30"
Rim diameter setting range for truck wheels	12" ÷ 30"
Maximum wheel/machine distance	400 mm
Maximum wheel width (with guard)	700 mm
Maximum wheel diameter (with guard)	1220 mm
Maximum wheel diameter (without guard)	1380 mm
Maximum wheel weight	200 kg
Power supply	115V 60Hz / 230V 50Hz 1ph
Total power absorption	220 W
Weight of the machine (with guard)	242 kg

## Technical Data

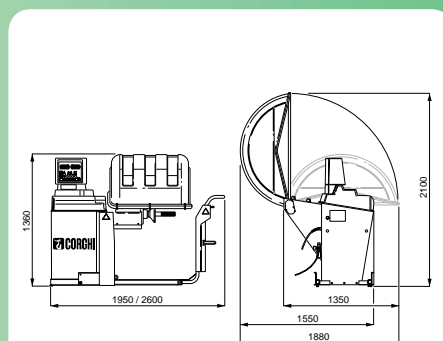

## Principal characteristics

- Electronic balancing machine with microprocessor for off-vehicle wheels of trucks, buses and vans
- **Low balancing speed** (80 rpm for truck wheels and 120 rpm for car wheels) reduces wheel spin times, reduces the risks due to rotating parts and saves energy
- **Automatic detection** of the type of wheel fitted (car or truck)
- **Automatic sensor** for measuring the distance and for the application of adhesive weights in Alu P programs
- **Automatic position search** (RPA): on completion of the wheel spin, the machine automatically positions the wheel in the weight application point
- Automatic wheel clamping at the end of the spin
- Wheel-holder shaft clamping brake
- STOP button for immediate machine shutdown
- **Lift equipped with safety handle** to prevent wheel roll-over and to facilitate handling procedures. The safety handle is also a handy flanges- and accessories holder
- Cover with trays to take weights of all kinds and the most commonly used accessories
- **Automatic start** when protective guard is lowered
- Luminous digital dual display with 3D graphics
- Simple, user-friendly keyboard for data input and program selection
- Processing unit with 16 bit microprocessor
- 1g (1/10oz) resolution in car function and 10g (0,5oz) in truck function
- Unbalance values displayed in grams or ounces
- Option of displaying unbalances rounded up/down
- Balancing modes available:
  - Standard dynamic on both sides of the rim
  - Alu / Alu P seven different options for alloy wheels (with profile measurement)
  - Static on one plane only

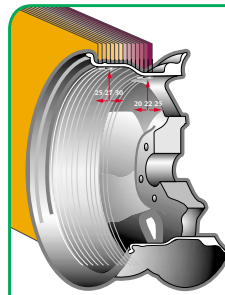

“**Shift Plane**” program (in Alu P mode) for use of weights in multiples of five grams, with no need for partial cuts (Corghi Patent)



“**Hidden Weight**” program (in Alu P) which subdivides the adhesive weight for the outside into two equivalent weights positioned behind the spokes of the rim

- “**OPT flash**” program for the rapid optimising of wheel running noise levels. A single tyre shift on the rim and a balancing spin will cause the machine to display:
  - the real wheel unbalance (the OPT procedure is completed if this is within the acceptable range)
  - the minimum unbalance which is obtained by further rotating the tyre on the rim
- Utility programs:
  - calibration
  - service
  - diagnostics
- **Three work environments** which allow three different operators to work at the same time without having to reset the data
- **VEI (Visual Eccentricity Inspection)**, to check for wheel and rim roundness defects



➤ Lift equipped with safety handle to prevent wheel roll-over and to facilitate handling procedures



➤ Control panel with dual display and 3D graphics

 **CORGHI**

This product has been certified by:

