

UG-65 & UG-650 SERIES HORIZONTAL GRINDERS

EXPLODED VIEW

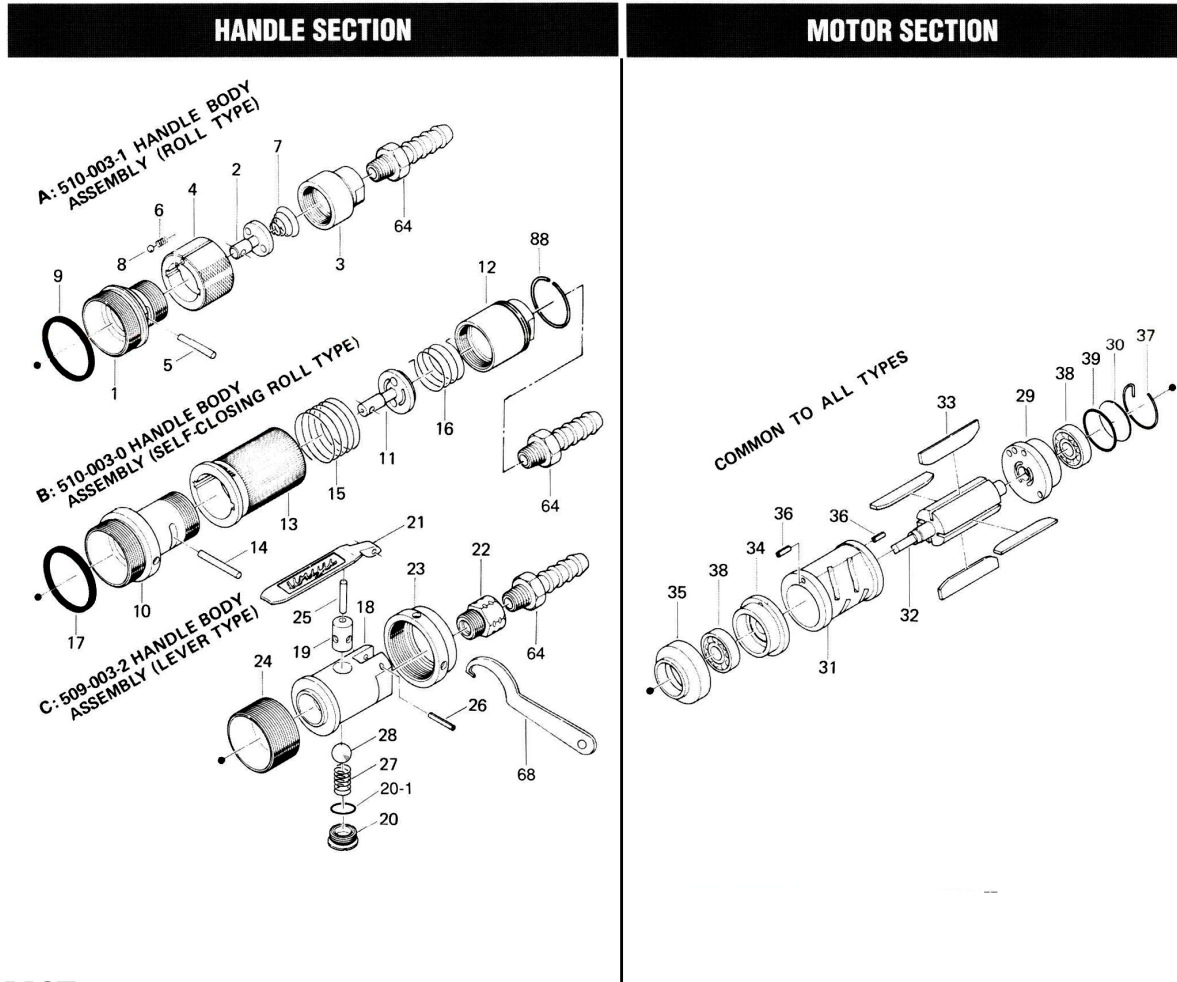

PARTS LIST — FOR REFERENCE ONLY

Index Number	Part Number	Description	Qty.	Index Number	Part Number	Description	Qty.	Index Number	Part Number	Description	Qty.
HANDLE SECTION											
A	510-981-1	HANDLE BODY ASSEMBLY (ROLL TYPE)	1	17	990-929-0	O-Ring (SNS-36)	1 ●	31	510-286-1	Cylinder	1
1	510-014-1	Handle Body	1	88	978-341-0	Snap Ring (34 x 2)	1	32	510-287-7	Rotor	1
2	510-100-1	Valve	1	C 509-003-2 HANDLE BODY ASSEMBLY (LEVER TYPE)				33	510-288-1	Blade	4 ●
3	509-091-1	Air Inlet Bushing	1	18	509-014-2	Handle Body	1	34	510-289-1	Front Plate	1
4	510-015-1	Valve Handle	1	19	509-102-2	Valve Seat	1	35	510-295-1	Cylinder Setter	1
5	971-271-0	Pin (3.8 x 30)	1	20	203-108-1	Valve Plug	1	36	973-110-0	Roll Pin (3 x 10)	2
6	976-027-0	Spring (3 x 11)	1	20-1	990-908-0	O-Ring (SNS-10)	1	37	978-310-0	Snap Ring (31 x 1.2)	1
7	977-080-0	Cone Spring (7 x 18 x 10)	1	21	425-107-1	Valve Lever	1	38	982-024-0	Ball Bearing (629)	2 ●
8	981-003-0	Ball (5/32)	1	22	418-091-1	Air Inlet Bushing	1	39	990-920-0	O-Ring (SNS-25)	1
9	990-929-0	O-Ring (SNS-36)	1	23	509-081-2	Handle Body Locking Nut	1	SPINDLE SECTION			
B	510-003-0	HANDLE BODY ASSEMBLY (SELF-CLOSING ROLL TYPE)	1	24	509-035-2	Casing Connector	1	D	3/8"-24 UNF SPINDLE FOR UG-65 SERIES		
10	510-014-0	Handle Body	1	25	970-322-0	Pin (H) (4 x 22)	1	40	509-390-1	Wheel Spindle	1
11	566-100-7	Valve	1	26	973-120-0	Roll Pin (3 x 20)	1	E 3/8"-24 UNF SPINDLE FOR UG-650 SERIES			
12	509-091-0	Air Inlet Bushing	1	27	976-232-0	Spring (9.5 x 18)	1	41	509-390-4	Extended Wheel Spindle	1
13	566-015-7	Valve Handle	1	28	981-210-0	Ball (3/8)	1	COMMON TO ALL SPINDLES			
14	971-273-0	Pin (3.8 x 34)	1	MOTOR SECTION				42	974-010-0	Key (3x10)	1 ●
15	976-720-0	Spring (33.8 x 15)	1	COMMON TO ALL MODELS				43	978-137-0	Snap Ring (12.7 x 1.2)	1 ●
16	976-976-0	Spring (25 x 35)	1	29	510-285-2	Rear Plate	1	44	975-220-0	Spacer (28 x 22 x 1)	1
				30	510-291-1	Rear Plate Spacer	1	45	510-392-1	Wheel Spindle Spacer	1
								46	982-101-0	Ball Bearing (6001)	1 ●



10000 SE PINE
PORTLAND, OR 97216
503-254-6600
FAX 503-255-2615

When ordering spare parts, please specify tool type, part number, and description.

FOOTNOTES

● = Items in Repair Kit UG-65-RK

UG-65 & UG-650 SERIES HORIZONTAL GRINDERS

SPINDLE SECTION

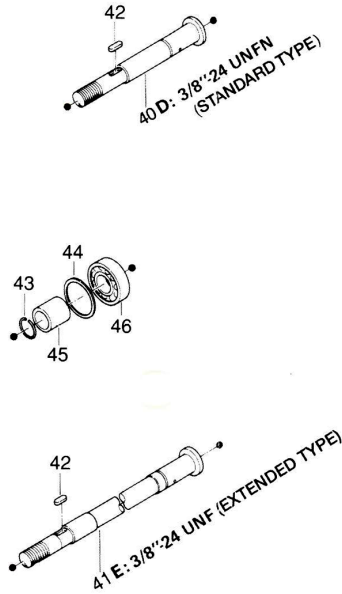

CASING SECTION

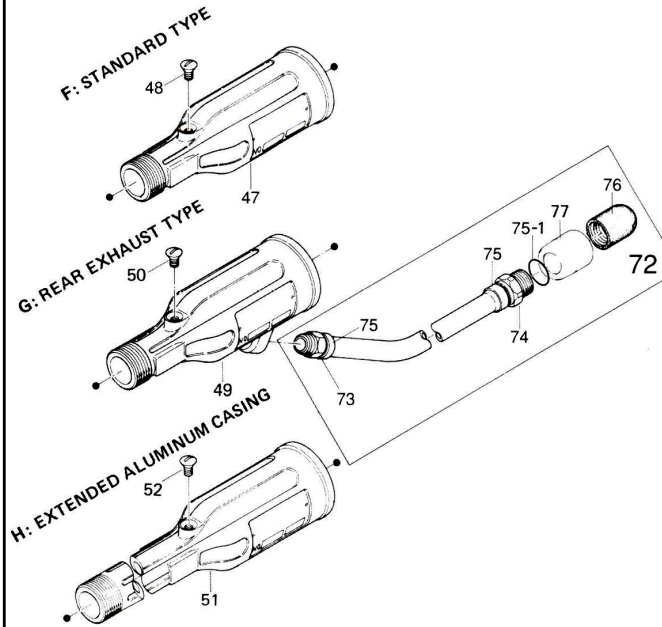

WHEEL SETTING SECTION

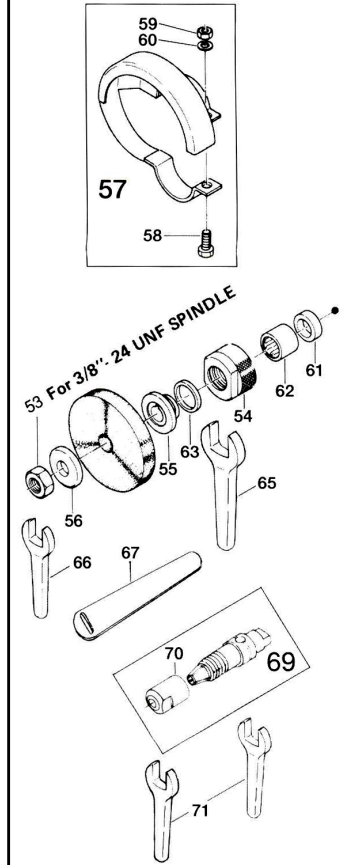

Index Number	Part Number	Description	Qty.
--------------	-------------	-------------	------

CASING SECTION

F: STANDARD TYPE			
47	510-025-1	Casing	1
48	949-208-0	Oval Flush Head Screw (M5 x 8)	1
G: REAR EXHAUST TYPE			
49	510-025-6	Casing	1
50	949-208-0	Oval Flush Head Screw (M5 x 8)	1
H: EXTENDED TYPE			
51	511-025-1	Casing	1
52	949-208-0	Oval Flush Head Screw (M5 x 8)	1

WHEEL SETTING SECTION

3/8" - 24 UNF SPINDLE			
53	960-601-0	Hexagon Nut (UNF 3/8" - 24 Spindle)	1
54	510-065-1	Casing Front Cover	1
55	510-393-1	Wheel Holder Flange	1
56	510-394-1	Wheel Nut Flange	1
57	510-770-1	Wheel Guard	1
58	946-900-0	Hexagon Head Bolt (M5 x 18)	1
59	960-037-0	Hexagon Nut (1-M5)	1
60	962-008-0	Spring Washer (2-55)	1
61	975-093-0	Spacer (18 x 12.5 x 6)	1
62	988-550-0	Needle Roller Bearing (TR-121815)	1
63	993-005-0	Felt Ring (15 x 20 x 3)	1

Index Number	Part Number	Description	Qty.
--------------	-------------	-------------	------

STANDARD ACCESSORIES

65	936-051-0	Spanner (17 x 3.2 x 135)	1
66	936-517-0	Spanner (17)	1
67	939-101-0	Spanner Holder (3.5 x 7.5 x 120)	1
Only for Lever-Type			
68	937-065-0	Spanner (4.8 x 22 x 153)	1

OPTIONAL ACCESSORIES

69	923-530-0	Collet Chuck Assembly (6 mm) (UNF3/8-24)	1
	923-532-0	Collet Chuck Assembly (1/4") (UNF3/8-24)	1

Index Number	Part Number	Description	Qty.
--------------	-------------	-------------	------

70	505-412-1	Chuck Nut	1
71	936-514-0	Spanner (14) (for Collet Chuck)	2
Only for Rear Exhaust Type			
72	934-325-0	Exhaust Hose Assembly (3/8 x 200 mm)	1
73	510-082-6	Connecting Screw	1
74	510-781-6	Exhaust Stack Bushing	1
75	510-789-6	Exhaust Stack Cover	2
75-1	990-912-0	O-Ring (SNS-14)	1
76	606-780-1	Exhaust Stack	1
77	612-778-0	Nylon Protector	1

Guide for Model Selection

Model	Wheel Mounting Section	Casing Section	Spindle Section	Motor Section	Handle Section
UG-65E	Common	F	D	Common	A
UG-65ER	Common	F	D	Common	B
UG-65EL	Common	F	D	Common	C
UG-65EB	Common	G	D	Common	A
UG-65EBR	Common	G	D	Common	B
UG-65EBL	Common	G	D	Common	C
UG-650E	Common	H	E	Common	A
UG-650ER	Common	H	E	Common	B
UG-650EL	Common	H	E	Common	C

UG-65-RK

(Kit contains following parts)

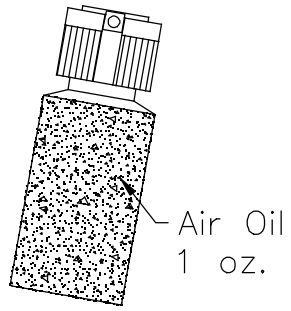
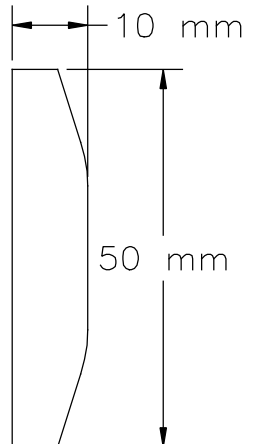
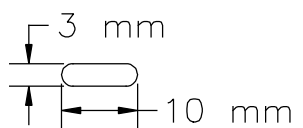
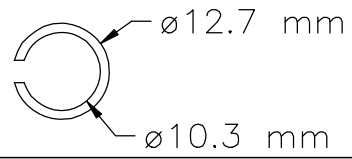
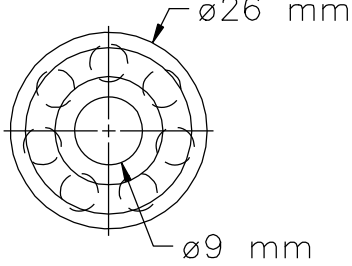
#/#	Bin Location	Part Number	QTY	Description	Material	Drawing / Scketch
1	SEWALL	AM-OIL	1	Oil Air Motor 1 oz. fluid	Plastic Container	
2	PA2C	510-288-1	4	Blade 10x50x1.85	Phenolic-Fiber	
3	PA4K	974-010-0	1	Key (3x10) 3x10x3	Steel	
4	PA4K	978-137-0	1	Snap Ring 12.7x1.2	Spring Wire 1.2 mm	
5	PA2H	982-024-0	2	Ball Bearing(629) 9x26x8	Bearing Steel	

UG-65-RK

(Kit contains following parts)

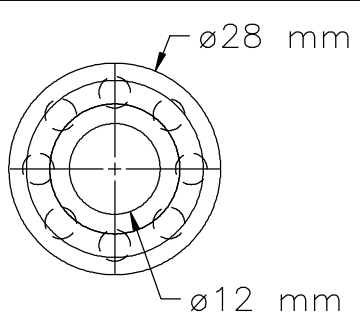
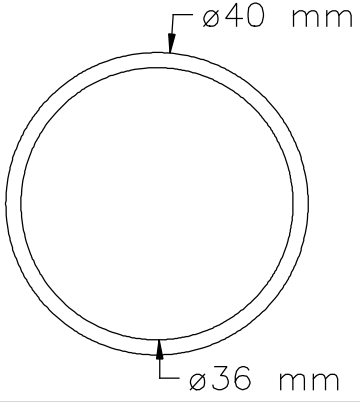
#/#	Bin Location	Part Number	QTY	Description	Material	Drawing / Scketch
6	PA2H	982-101-0	1	Ball Bearing(6001) 12x28x8	Bearing Steel	 <p>Technical drawing of a ball bearing (6001) showing dimensions: outer diameter $\varnothing 28$ mm and inner diameter $\varnothing 12$ mm.</p>
7	PA1B	990-929-0	1	O-Ring (SNS-36) 36x40x2	Buna-Black	 <p>Technical drawing of an O-ring (SNS-36) showing dimensions: outer diameter $\varnothing 40$ mm and inner diameter $\varnothing 36$ mm.</p>